

TOP VIEW

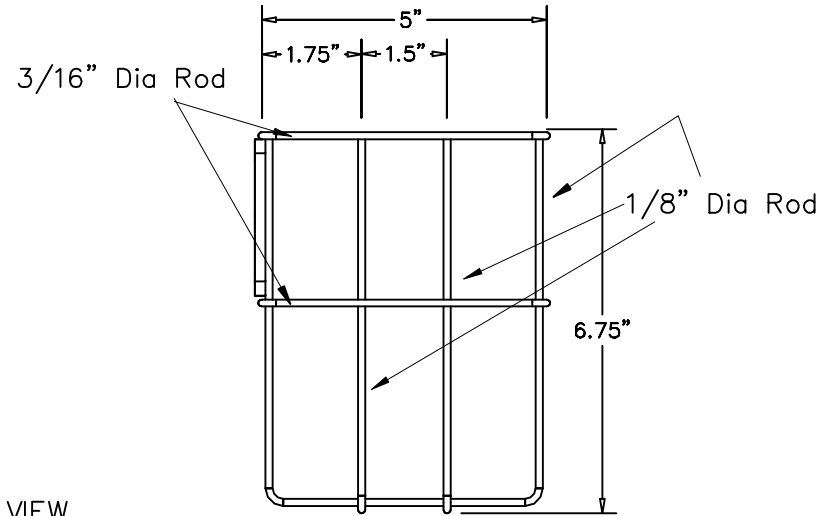

SIDE VIEW

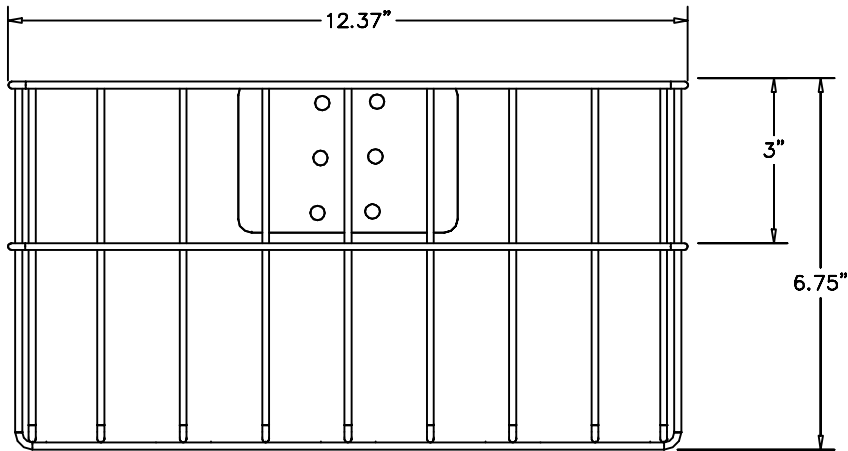

FRONT VIEW

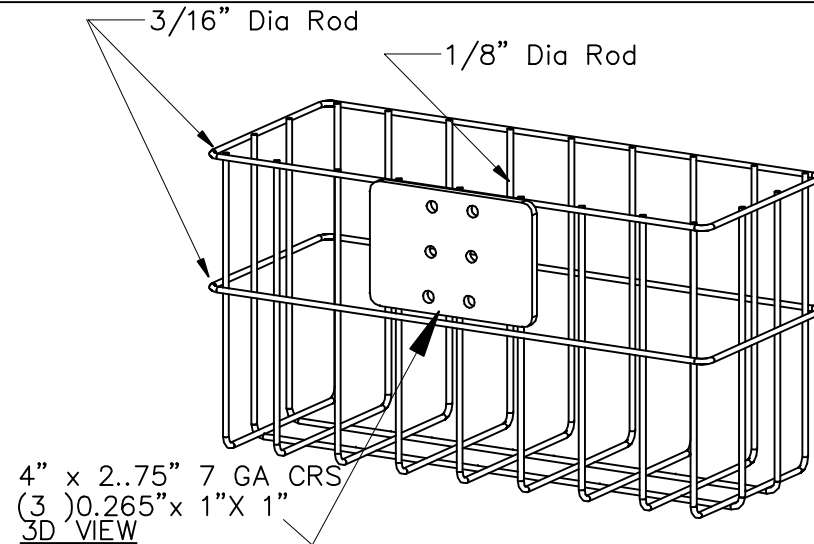

4" x 2.75" 7 GA CRS
(3) 0.265" x 1" X 1"
3D VIEW

NOTES :

MATERIAL :
AS NOTED ABOVE

TOLERANCES UNLESS OTHERWISE SPECIFIED
FRACTIONAL ±1/64
2 PLC. DEC. ±.01
3PLC. DEC. ±.001
ANGULAR ±.5°
FINISH √

DRAWN BY : VGM

DATE: 03/10/05

DESCRIPTION :

wire basket

A P P R O V E D

ENG :

MFG :

QA :

SCALE : N.T.S.

SHEET : 1 OF 1

USED ON :

PATH : Accessories\Wire Basket

NUMBER : WB100-WM

FOLDER :

REV: SIZE
A